



# Raise3D Filament Dry Box

# User Manual



📍 43 Tesla, Irvine, CA 92618, USA  
☎ +1 888 963 9028

📍 Stationsplein 45 Unit A4.004 3013AK Rotterdam, the Netherlands

📍 Floor 4 B5, 1688 North Guoquan Road, Yangpu District Shanghai, China 200438  
☎ +86 21 65337855

🌐 [www.raise3d.com](http://www.raise3d.com)

# | CONTENTS

## 01 ○ Introduction & Essential Parts

Introduction  
Specifications  
Package Contents  
Essential Parts

## 03 ○ Safety Instructions

## 04 ○ Installation Guide

How to Install the Raise3D Premium Filament Spool  
How to Install the Non-Standard Filament Spool  
( $\Phi < 50\text{mm}$ )



The contents of this User Manual maybe updated overtime. For the latest version, scan the QR code or visit the link below.

<https://support.raise3d.com/E2CF/raise3d-filament-dry-box-user-manual-25-1403.html>

## Introduction

Thank you for purchasing the 3D printing Filament Dry Box from Raise3D!

Raise3D Filament Dry Box is an excellent choice for you to store and dry filaments. It can solve various problems caused by 3D printing filaments exposed to the air or absorbing moisture from the air.

Raise3D Filament Dry Box includes silica gel desiccant to absorb the moisture from the air. The Filament Dry Box maintains humidity levels below 25% (within one month), effectively preventing the 3D printing filaments from getting damp during storage and use. The Filament Dry Box is designed for carbon fiber composite filaments, nylon filaments, and other hydrophilic filaments.

Raise3D Filament Dry Box is made of high-quality materials, making it strong and durable. It can withstand collisions and drops to prevent damage to the filament tray. Raise3D Filament Dry Box is highly compatible. It can contain a spool of 1kg standard Raise3D Premium filament and non-standard filaments. It is compatible with both 1.75mm and 2.85mm filaments.

## Specifications

Desiccant type	Silica gel
Desiccant specifications	100g desiccant sachets(vacuum-packed) ×2
Supported filament spools	1kg (Standard shaft diameter ≥50 mm, Non-standard shaft diameter ≥28mm)
Humidity range	Humidity ≤ 25% within 1 month
Product size (L×W×H)	330×95×250mm
Packing size (L×W×H)	380×128×355mm
Net weight (excluding desiccant and filament)	1.9kg
Gross weight	2.25kg

## Package Contents

Raise3D Filament Dry Box × 1

100g Silica Gel Sachets(vacuum-packed) × 2

Metal Quick Connector × 1

Nut × 1

Guide Tube × 1

## Essential Parts

- ① Lid Cover
- ② Top Half of the Filament Tray
- ③ Inner Shaft
- ④ Removable Expander
- ⑤ Bottom Half of the Filament Tray
- ⑥ Desiccant Box
- ⑦ Desiccant Box Cover
- ⑧ Discharge Hole

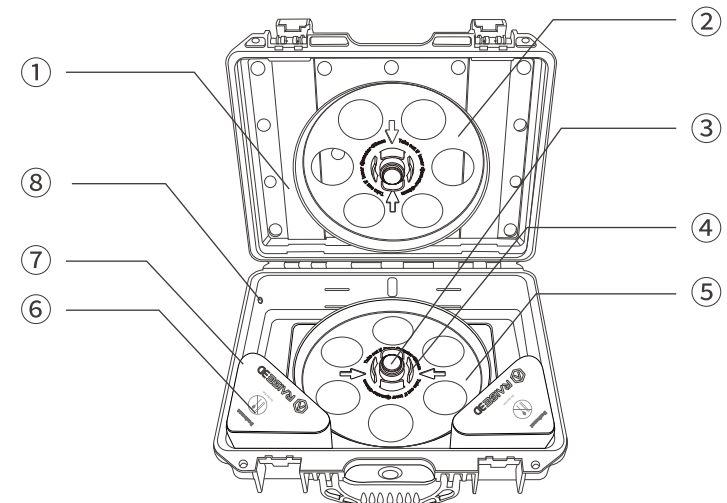

## Safety Instructions



Raise3D Filament Dry Box comes with silica gel desiccant sachets, which are safety verified, non-toxic, tasteless, non-corrosive, and non-polluting.



Do not eat the desiccant. Keep the desiccant out of the reach of children or pets. Keep the desiccant away from water or open flame. If accidentally swallowed or contacted with eyes, please flush with plenty of water and seek medical attention immediately.



Silica gel can absorb up to 10-40% of its weight depends on environment humidity. If the Filament Dry Box is kept open for a long time, the silica gel desiccants may lose some of its drying capacity. The used silica gel desiccants can be regenerated at 80-90°C for 8 hours to recover its drying capacity. Please regularly replace or regenerate the desiccants.



Raise3D Filament Dry Box contains small parts. Keep small parts out of the reach of children or pets. Small parts may be hazardous if swallowed or may cause choking if ingested or inhaled.

## How to Install the Raise3D Premium Filament Spool

1. Determine the position of the discharge hole according to the opening direction of the Filament Dry Box.



2. Open the accessory bag and take out the metal quick connector, nut, and guide tube.



3. Pull out the rubber plug from the discharge hole, install the quick connector and nut on both sides of the discharge hole and tighten them. Insert the guide tube from the outside into the quick connector tightly.



4. Put two bags of 100g silica gel desiccant into two desiccant boxes separately, and close the lids. Place the dried Raise3D filament spool on the tray, and feed the filament through the discharge hole, then close the Filament Dry Box.

**Note:** After use for a period of time, the moisture absorbing capacity of desiccant decreases. The ineffective silica gel can be regenerated at 80-90°C for 8 hours to restore its drying capacity. Some other types of desiccants may not have the ability to recover. It is not recommended to use other kinds of desiccants. For a better drying efficiency and printing result, please also dry the filament appropriately before printing.



5. Place the Filament Dry Box on one side of the Raise3D E2CF printer. It is recommended that the discharge port face the front of the printer when placing the Filament Dry Box.



6. Insert the filaments into the metal quick connector on the side wall of the Raise3D E2CF. Gently push the filament until it is inserted into the extruder. The guide tube of the Filament Dry Box needs to be inserted into the metal quick connector. Do not unplug the guide tube from the filament run-out sensor inside the printer.



7. On the RaiseTouch, select "Utilities> Filament Loader> Load" to load the filament. Now you can start your first print!



## How to Install the Non-Standard Filament Spool ( $\Phi < 50\text{mm}$ )

1. Remove the tray by pressing the protruding part. Follow the arrow on the back of the tray to remove the removable expander.



2. Put the tray back into the Filament Dry Box, and then put the non-standard filament on the tray. The internal diameter of the non-standard filament spool is less than 50mm but greater than 28mm.



3. Gently pull out the filament from the guide tube, and load the filament into the extruder according to the previous steps.



## Experiencing Difficulties/Contact Information

If you run into any issues during this guided setup, please contact our expert technicians by opening a ticket online at [support.raise3d.com](https://support.raise3d.com).

